

ER2 Single Speed

With Hook Suspension

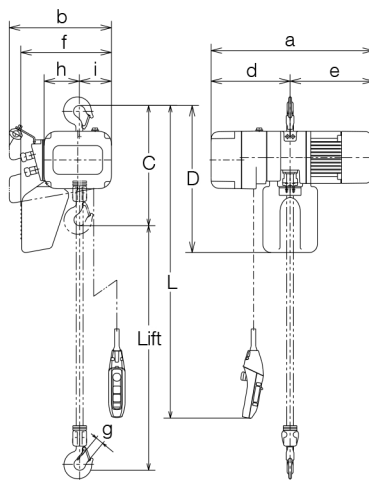

- Standard length of power supply cable is five meters.
- Optional length of lift, push button cord and power supply cable besides standard is available on your request.
- Extending the load chain is prohibited with additional links.
- Steel chain containers are available as option as shown in Section of "Chain Containers" if your lift is more than capacity of the standard container volume.

Specifications

Capacity (t)	Product Code	Hoist Body	Standard Lift (m)	Lifting Motor		Lifting Speed (m/min)		Load Chain		Classification ISO/FEM/ASME	Test Load (t)	Net Weight (kg)	Additional Weight per 1m Lift (kg)
				Output (kW)	Rating (%ED)	50Hz	60Hz	Diameter (mm)	x Chain Falls				
125kg	ER2-001H	B		0.56		14.1	16.9	ø4.3	x 1		156kg	27	0.42
250kg	ER2-003S					9.1	10.9				313kg		
	ER2-003H	13.4	16.1	M5/2m/H4	625kg	33	0.81						
500kg	ER2-005L	C			0.56		3.8	4.6	ø6.0	x 1		1.25	37
	ER2-005S			0.9		7.3	8.8	47					
1	ER2-010L	D	3	60		3.5	4.2	ø7.7	x 1		1.88	54	2.3
	ER2-010S				7.1	8.5	73						
1.5	ER2-015S	E			1.8	4.5	5.4	ø10.2	x 1		2.5	72	2.8
2	ER2-020L				3.7	4.4	91						
	ER2-020S	7.0	8.4	M4/1Am/H4	3.13	104	2.8						
2.5	ER2-025S	F				3.5	5.7	6.8	ø11.2	x 1	3.75	107	4.7
3	ER2-030S	E			4.4	5.3	ø10.2	x 2	6.25	132	5.6		
5	ER2-050S	F			2.9	3.5	ø11.2	x 2					

Dimensions (mm)

Capacity (t)	Product Code	Headroom C	D	a (MFC)	b (MFC)	d (MFC)	e (MFC)	f (MFC)	g	h	i (MFC)
125kg	ER2-001H	350	430	478(564)	321(345)	219(305)	259	260(284)	27	99	93(117)
250kg	ER2-003S			510(593)		268					
	ER2-003H			271(273)	283	27	113	106			
500kg	ER2-005L	370	490	513(599)	348	242(325)	271(273)	283	27	113	106
	ER2-005S			510(593)		268					
1	ER2-010L	430	550	589(632)	376	291(332)	298(300)	335	31	129	118
	ER2-010S			598(639)			307				
1.5	ER2-015S	510		646(738)	427	308(397)	338(341)	384.5	34	160.5	137.5
2	ER2-020L	575	630	703(782)			347(426)				
	ER2-020S	590									
2.5	ER2-025S	625	840	736(826)	445	337(427)	399	437.5		173.5	142.5
3	ER2-030S	785		703(782)	427	347(426)	356	397	44	216	82
5	ER2-050S	850	920	736(826)	445	337(427)	399	439	47	231.5	84.5

Note: Figures in () are data for mechanical brake with friction clutch.