

ER2 Dual Speed inverter

With Hook Suspension

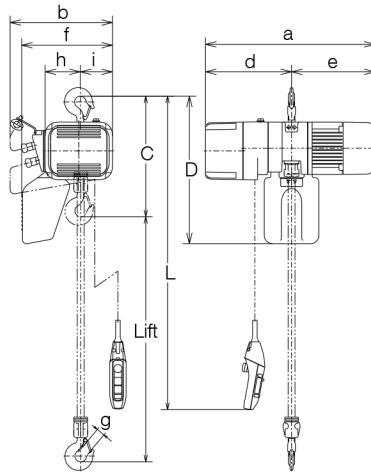

- Standard length of power supply cable is five meters.
- Optional length of lift, push button cord and power supply cable besides standard is available on your request.
- Extending the load chain is prohibited with additional links.
- Steel chain containers are available as option as shown in Section of "Chain Containers" if your lift is more than capacity of the standard container volume.
- Lifting Speed in catalogue is at the rated load. It may vary depending on actual load.

Specifications

Capacity (t)	Product Code	Hoist Body	Standard Lift (m)	Lifting Motor		Lifting Speed (m/min)*			Load Chain		Classification ISO/FEM/ASME	Test Load (t)	Net Weight (kg)	Additional Weight per 1m Lift (kg)
				Output (kW)	Rating (%ED)	50/60Hz		Diameter (mm)	x	Chain Falls				
				High	Low									
125kg	ER2-001IH	B		0.56		Preset	16.6	2.8	ø4.3	x	1	156kg	27	0.42
250kg	ER2-003IS					Adjustable		1.4						
	250kg	ER2-003IH	C	0.9		Preset	10.8	1.8	ø6.0	x	1	313kg	36	
ER2-003IH		Adjustable					0.9							
500kg	ER2-005IL	C	3	0.56		Preset	15.7	2.6	ø7.7	x	1	625kg	32	0.81
	ER2-005IS					Adjustable		1.3						
1	ER2-010IL	D	3	0.9	40/20	Preset	4.5	0.8	ø10.2	x	1	1.25	45	1.33
	ER2-010IS					Adjustable		0.4						
1.5	ER2-015IS	E		1.8		Preset	8.5	1.4	ø11.2	x	1	3.13	100	2.8
						Adjustable		0.7						
2	ER2-020IL	E		3.5		Preset	4.2	0.7	ø10.2	x	1	2.5	73	2.3
						Adjustable		0.3						
2.5	ER2-020IS	F		3.5		Preset	8.2	1.4	ø11.2	x	2	3.75	105	4.7
						Adjustable		0.7						
3	ER2-025IS	F		3.5		Preset	5.3	0.9	ø11.2	x	2	6.25	128	5.6
						Adjustable		0.4						
5	ER2-030IS	E		3.5		Preset	4.3	0.7	ø11.2	x	2	3.13	100	2.8
						Adjustable		0.4						
2.5	ER2-025IS	F		3.5		Preset	8.2	1.4	ø11.2	x	2	3.75	105	4.7
						Adjustable		0.7						
3	ER2-030IS	E		3.5		Preset	6.6	1.1	ø11.2	x	2	6.25	128	5.6
						Adjustable		0.6						
5	ER2-050IS	F		3.5		Preset	5.2	0.9	ø11.2	x	2	6.25	128	5.6
						Adjustable		0.4						
5	ER2-050IS	F		3.5		Preset	3.3	0.6	ø11.2	x	2	6.25	128	5.6
						Adjustable		0.3						

Note: The high speed is preset to the maximum speed in KITO factory. The speeds are adjustable between High and Low. Figures in () are data for mechanical brake with friction clutch.

Dimensions (mm)

Capacity (t)	Product Code	Headroom C	D	a (MFC)	b	d (MFC)	e (MFC)	f	g	h	i
125kg	ER2-001IH	350	430	535(564)	345	276(305)	259	284	27	99	117
250kg	ER2-003IS			568(593)							
	ER2-003IH	370	490	571(598)	348	300(325)	271(273)	283	27	113	106
500kg	ER2-005IS			568(593)							
1	ER2-010IL	430	550	614(632)	376	316(332)	298(300)	335	31	129	118
	ER2-010IS			623(639)							
1.5	ER2-015IS	510	630	710(737)	427	372(397)	338(340)	384.5	34	160.5	137.5
				ER2-020IS							
2	ER2-020IL	575	630	710(737)	427	372(397)	338(340)	384.5	34	160.5	137.5
				ER2-020IS							
2.5	ER2-025IS	625	840	800(826)	445	401(427)	399	437.5	44	216	82
				ER2-030IS							
3	ER2-030IS	785	920	800(826)	445	401(427)	399	439	47	231.5	84.5
				ER2-050IS							

Note: Figures in () are data for mechanical brake with friction clutch.