

ER2 Dual Speed 500V pole change

With Hook Suspension

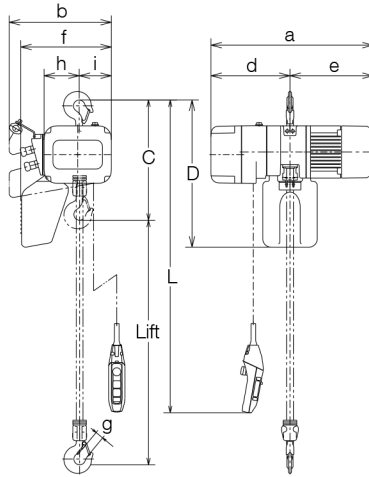

- Standard length of power supply cable is five meters.
- Optional length of lift, push button cord and power supply cable besides standard is available on your request.
- Extending the load chain is prohibited with additional links.
- Steel chain containers are available as option as shown in Section of "Chain Containers" if your lift is more than capacity of the standard container volume.

Specifications

Capacity (t)	Product Code	Hoist Body	Standard Lift (m)	Lifting Motor		Lifting Speed (m/min)	Load Chain		Classification ISO/FEM/ASME	Test Load (t)	Net Weight (kg)	Additional Weight per 1m Lift (kg)
				Output (kW)	Rating (%ED)		Diameter (mm)	Chain Falls				
125kg	ER2-001HD	B	3	0.5/0.13	40/20	14.2/3.5	ø4.3	x 1	M5/2m/H4	156kg	31	0.42
250kg	ER2-003SD					7.2/1.8				313kg		
500kg	ER2-005LD	C	3	0.9/0.23	40/20	3.6/0.9	ø6.0	x 1	M5/2m/H4	625kg	39	0.81
	ER2-005SD					7.1/1.8					43	
1	ER2-010LD	D	3	0.9/0.23	40/20	3.5/0.9	ø7.7	x 1	M5/2m/H4	1.25	56	1.33
	ER2-010SD					7.2/1.7					58	
1.5	ER2-015SD	E	3	1.8/0.45	40/20	4.8/1.2	ø10.2	x 1	M4/1Am/H4	1.88	74	2.3
2	ER2-020LD					3.7/0.9				76		
	ER2-020SD	6.9/1.6	97									
2.5	ER2-025SD	F	3	3.5/0.88	40/20	5.5/1.3	ø11.2	x 1	M4/1Am/H4	3.13	108	2.8
3	ER2-030SD	E	3	3.5/0.88	40/20	4.4/1.0	ø10.2	x 2	M4/1Am/H4	3.75	113	4.7
5	ER2-050SD	F	3	3.5/0.88	40/20	2.8/0.6	ø11.2	x 2	M4/1Am/H4	6.25	134	5.6

Dimensions (mm)

Capacity (t)	Product Code	Headroom C	D	a (MFC)	b (MFC)	d (MFC)	e (MFC)	f (MFC)	g	h	i (MFC)
125kg	ER2-001HD	350	430	478 (564)	321 (345)	219 (305)	259	260 (284)	27	99	93 (117)
250kg	ER2-003SD			513 (598)	348	242 (325)	271 (273)	283	27	113	106
500kg	ER2-005LD	370	490	533 (616)	376	291 (332)	291	335	31	129	118
	ER2-005SD			589 (632)			298 (300)				
1	ER2-010LD	430	550	615 (656)	376	291 (332)	324	335	31	129	118
ER2-010SD	646 (737)			427			308 (397)				
2	ER2-020LD	575	630	737 (816)	427	347 (426)	390	397	44	216	82
	ER2-020SD	590		736 (826)			445				
2.5	ER2-025SD	625	840	736 (826)	445	337 (427)	399	437.5	44	216	82
3	ER2-030SD	785	920	737 (816)	427	347 (426)	390	397	44	216	82
ER2-030SD	736 (826)	445		337 (427)							
5	ER2-050SD	850	920	736 (826)	445	337 (427)	399	439	47	231.5	84.5

Note: Figures in () are data for mechanical brake with friction clutch.